

Installation manual

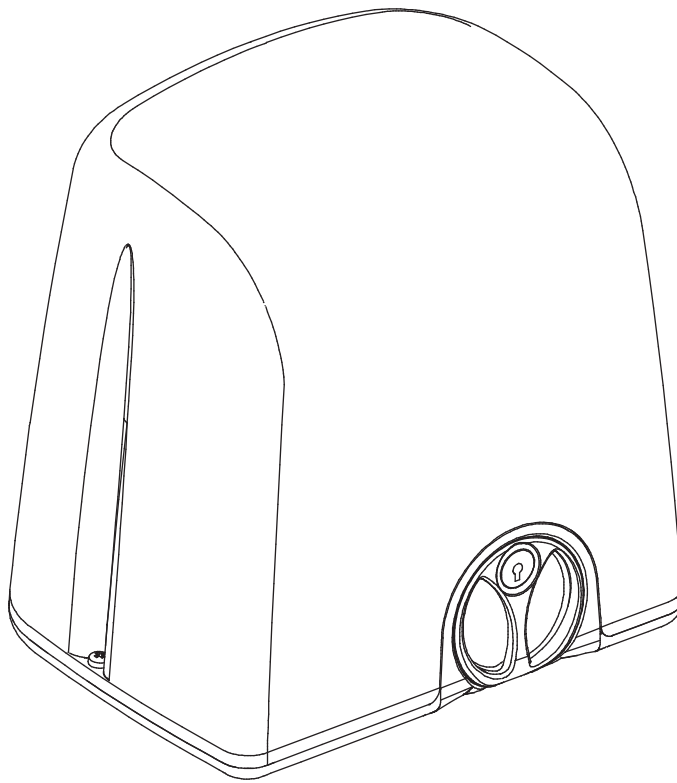

English



myStrike

OPENER FOR RACK-DRIVEN
SLIDING MOTOR

1. WARNINGS AND GENERAL SAFETY INSTRUCTIONS

This manual contains important safety information.

An incorrect installation or an improper use may cause serious damages to persons or objects.

Read this manual carefully and completely. Pay particular attention to the sections marked by the symbol: 

This indicates that risk to personal injury may occur if not adhered to. Store this manual safely for future use.



Always disconnect main power supply before operating in the automatic gate.



Make sure that the earth system is perfectly working and always connect the automatic gate to it.

The installation of automatic gates and doors must fully comply with the requirements set forth in 2006/42/EC Directive, with particular reference to EN 12453 standards.

The final connection to the electrical mains, testing and start-up of the automation must be performed by skilled and qualified personnel (professional gate installers), who is responsible for carrying out the risks analysis and verifying the compliance of the system with the current safety standards.

This product is exclusively designed and manufactured for the intended use specified in this manual. Any other use than stated could compromise the integrity and the safety of the product and therefore is strictly prohibited. The automation is designed to move driveway gates and not intended to be used for any other purpose.



Do not let children play with the radio transmitters and any other device which could accidentally start the gate automation.

Use exclusively original parts by manufactured by Proteco for maintenance.

Do not carry out any alteration on the components of the automatic gate.

The manufacturer declines all liability in case components or additional devices not produced by myGate.

EU DECLARATION OF CONFORMITY AND DECLARATION OF INCORPORATION OF PARTLY COMPLETED MACHINERY

In accordance with Annex II B of Machinery Directive 2006/42/CE

The legal representatives of

myGate is a trademark by PROTECO S.r.l.

Manufacturer: PROTECO S.r.l.

Address: Via Neive, 77 – 12050 Castagnito (CN) – ITALIA

declares that

The product type: **myStrike** Electromechanical gear motor for sliding gate

Models: **myStrike 5, myStrike 6, myStrike 8, myStrike 5 115, myStrike 8 115**



Proteco S.r.l.
via Neive 77, 12050 Castagnito (CN) Italia
tel (+39) 0173210111 - fax (+39) 0173210199
www.proteco.net - info@proteco.net

comply the following Essential Requirements of directive 2006/42/CE Allegato I (direttiva Macchine):

1.1.2 - 1.1.3 - 1.1.5 - 1.2.1 - 1.2.2 - 1.2.3 - 1.2.6 - 1.3.2 - 1.3.4 - 1.3.9 - 1.4.1 - 1.4.2.1 - 1.5.1 - 1.5.4 - 1.5.6 - 1.5.8 - 1.5.13 - 1.6.1 - 1.6.4 - 1.7.1 1.7.3 1.7.4

are in conformity with the following directives:

2014/30/UE (EMC)

2011/65/CE (RoHS2)

2014/35/UE (LVD)

The above listed products are delivered, limitedly to the applicable parts, according to the following standards:

EN 12453

Industrial, commercial and garage doors and gates. Safety in use power operated doors. Requirements.

EN60335-1

Household and similar electrical appliances - Safety - Part 1: General requirements.

EN60335-2-103

Household and similar electrical appliances - Safety - Part 2-103: Particular requirements for drives for gates, doors and windows.

They also state that:

- the relevant technical documentation is compiled in accordance with part B of Annex VII of directive 2006/42/CE

- the relevant technical documentation is compiled and preserved by Proteco S.r.l. which undertakes to transmit it by mail in response to a reasoned request by the national authorities.

- the partly completed machinery must not be put into service until the final machinery into which it is to be incorporated has been declared in conformity with the provisions of the directive 2006/42/CE

Castagnito, 08/05/2020

Marco Gallo
Managing Director

2. PRODUCT DESCRIPTION AND INTENDED USE

myStrike gear motor is designed to automate residential or commercial sliding gate with rack.

Any other use than above described has to be considered as inappropriate and strictly prohibited.

All models feature an irreversible gearing system that locks the gate when it is in its fully closed position. Therefore no additional lock is needed. In case of a power failure the motor lock can be released to move the gate manually.

2.1 TECHNICAL SPECIFICATIONS

	myStrike 5	myStrike 6	myStrike 8	myStrike 5 115	myStrike 8 115
Power supply	230V ~ 50Hz	24Vdc	230V ~ 50Hz	115V ~ 60Hz	115V ~ 60Hz
Current	1,2 - 1,7A	0,7 - 10A	1,2 - 2A	2,0 - 2,3A	2,8 - 3,2A
Motor power	250W	80W	300W	280W	330W
Capacitor	8µF	-	10µF	30µF	30µF
Thermic Protection	150°C	-	150°C	150°C	150°C
Maximum thrust	350 N	500 N	440 N	380 N	460 N
Class IPProtection	44	44	44	44	44
Revolutions (speed)	1400 rpm	1600 rpm	1400 rpm	1700 rpm	1700 rpm
Opening speed	8,5 m/min	5 - 9 m/min	8,5 m/min	10 m/min	10 m/min
Gate maximum weight	500 Kg	650 Kg	800 Kg	500 Kg	800 Kg
Duty Cycle	40%	80%	40%	40%	40%

2.1 PACK CONTENTS

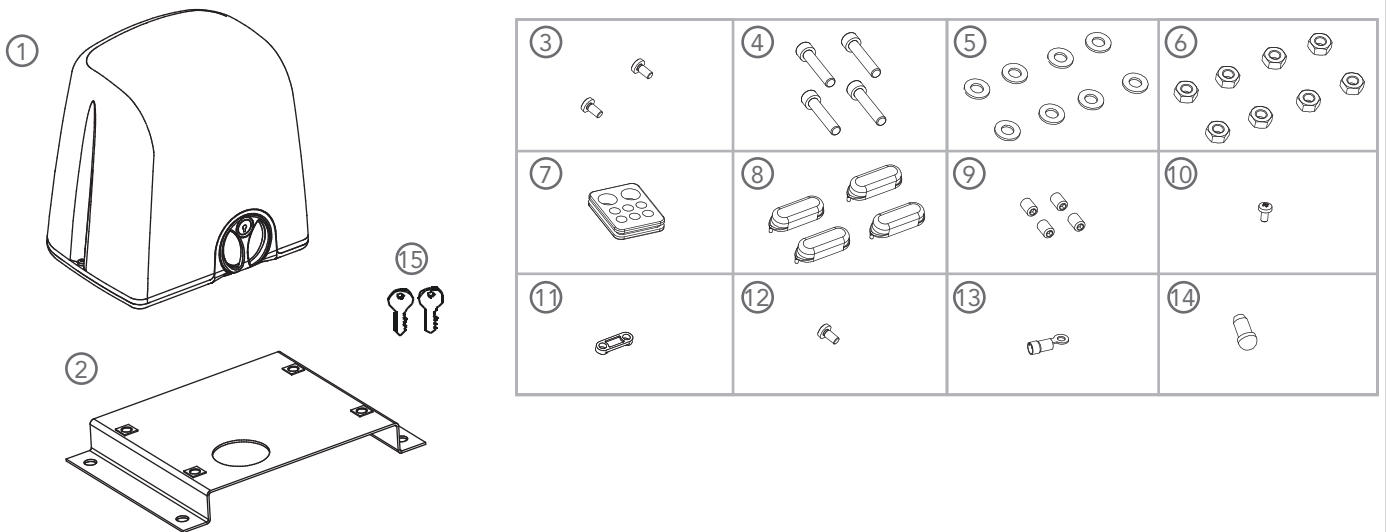

1	STRIKE	Gear motor
2	MPI504	Anchor plate
3	MVI0510B2	Screw 5x10 for cover
4	MVI1060AZ	Screw 10x60 for motor-anchor plate fixing
5	MRO10Z	Washer Ø10 for motor-anchor plate fixing
6	MDAM10Z	Nut Ø10 for motor-anchor plate fixing
7	MPC06	Cable grommet SH70
8	MTP22	Slot-cover
9	MGR0610Z	Limit bracket fixing screw 6x10 (for universal steel brackets only)
10	MVI3595D	Screw TC 3.5x9.5 for cable-block
11	MBC02	Black cable block
12	MVI0510B2	Screw TC 5x10 for lug
13	MFAG01	Yellow lug for earth system
14	MMA02	Limit-switch tip
15	MCH03	Release key

2.3 DIMENSIONS

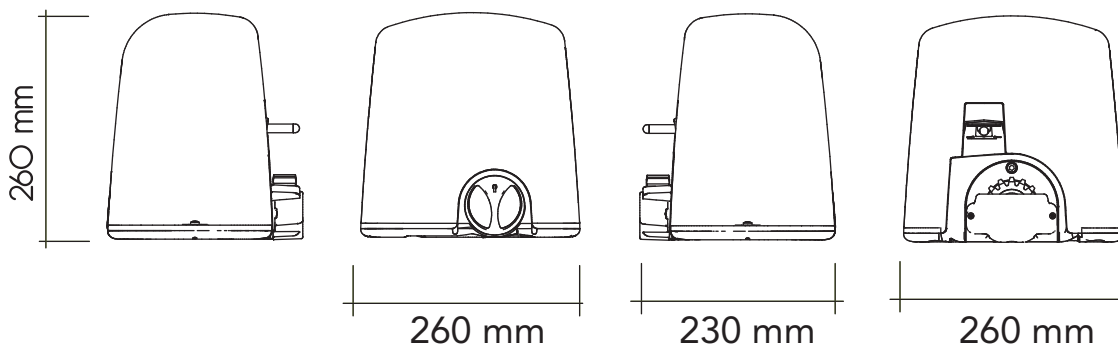

3. INSTALLATION

3.1 PRELIMINARY CHECKS

Before the installation, to ensure correct working of the automation, please check the followings:

- Make sure the gate's structure is suitable to be automated
- Check the weight, dimensions and type of the gate is appropriate to this type of automation
- Ensure the gate is able to open and close smoothly and is free of obstacles that may cause the gate to potentially derail
- Check the ground and all surfaces for the installation are suitable for stable and safe fixing of the gate automation.
- Make sure the installation area for the automation is wide enough to accommodate the anchor plate and the motor can be accessed easily in the event of power cuts.
- Ensure the location where the automation is installed is not exposed to flood hazards; if in doubt raise the automation from above ground level.
- In cases where the automation has to be installed in a vehicles path or manoeuvre area, it is recommended to protect it against accidental damage.
- Ensure an efficient earth connection system is in place.
- Make sure the surfaces for photocells fixing areas are flat and smooth enough to allow a perfect alignment between transmitting and receiving units. They must both directly see each other as they are not reflective.

3.2 ELECTRICAL SET-UP

3.2.1 STANDARD INSTALLATION

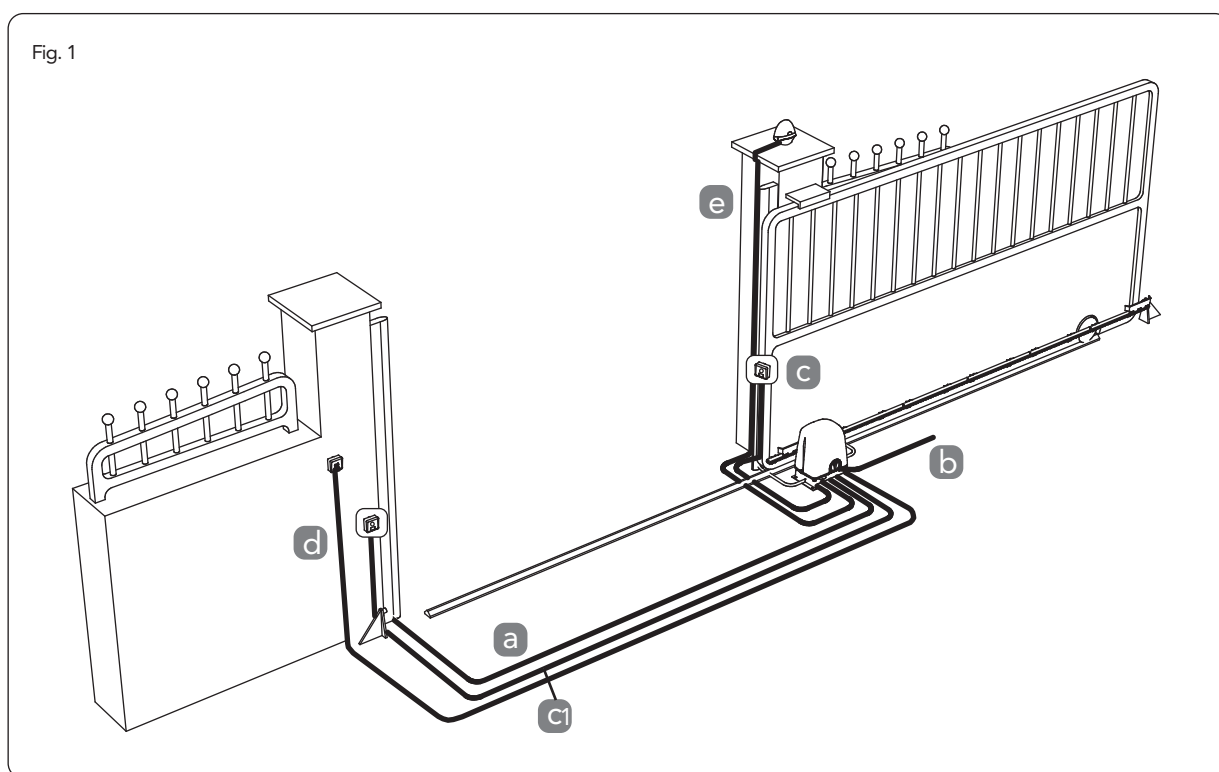

3.2.2 ELECTRICAL CABLES SPECIFICATIONS

The cables required the electrical set-up (not included in the pack) may vary according to quantity and type of devices installed.

	230V	24V
A Safety edge	2x0,50 mm ²	2x0,50 mm ²
B Power supply	2x1,50 + terra	2x1,50+T
C Photocells	rx 4x0,50 mm ²	rx 4x0,50 mm ²
C ¹ Photocells	tx 2x0,50 mm ²	tx 2x0,50 mm ²
D Key-switch	2x0,50 mm ²	2x0,50 mm ²
E Flashing light	2x0,50 mm ²	2x0,50 mm ²

3.3 TOOLS NEEDED

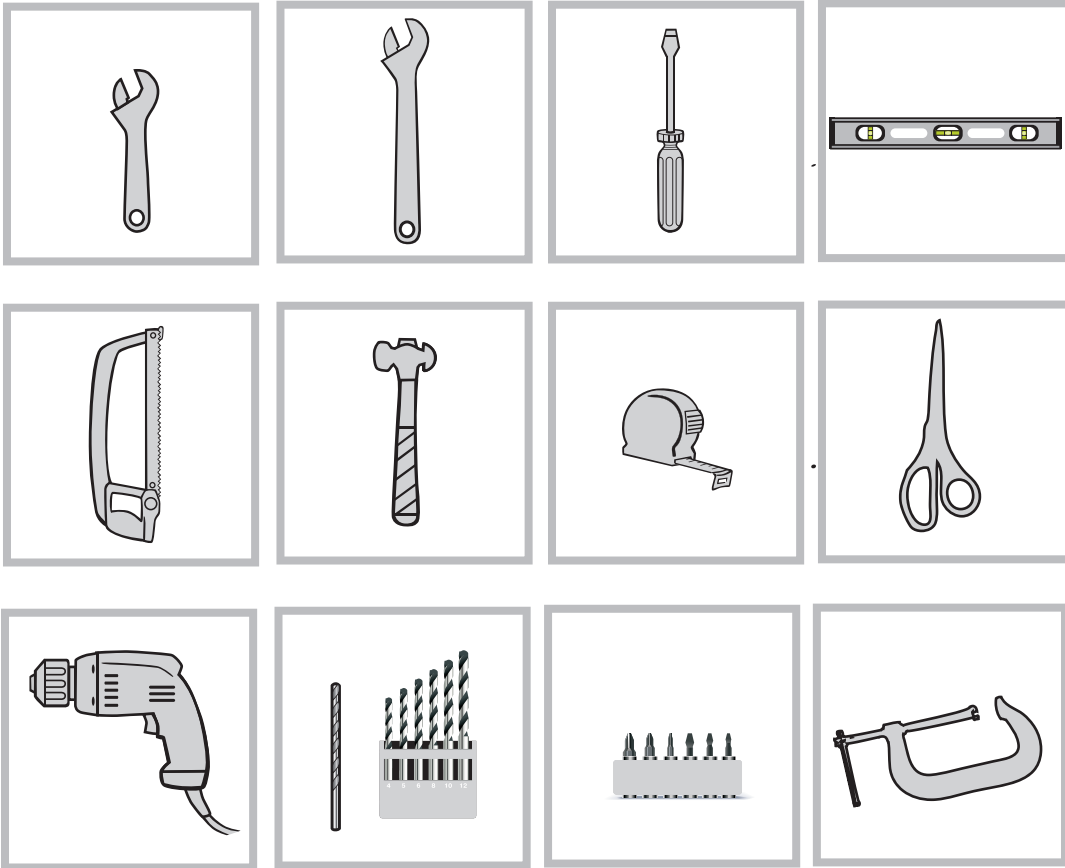

3.4 PRELIMINARY INSTALLATION WORK AND MASONRY FOR ANCHOR PLATE

Identify approximately the place of each component and proceed as follows:

- Dig the foundation pit for the gear motor whilst considering the anchor plate dimensions. Give an extra 5cm area extra on each side. Pay attention to measurements shown in Fig.2.
- Provide one or more ducts for the electrical cables so that they can easily go through the purpose fabricated hole in the gear motors anchor plate. Pay attention to the plate's orientation: hole for cables routing on the side opposite the gate (see Fig. 2).
- Set concrete into the pit. Ensure this is level and smooth out the surface. Wait for the concrete to get solidify (this may take a few days).
- Insert the cables ducting to the hole in the anchor plate and fix the plate to the concrete using suitable plugs.
- Cut the cable ducts about 3cm above the anchor plate level and route the cables for accessories and electrical mains wiring as shown in Fig. 3 diagram. Ensure the cables are at least 30-50cm out from the ducting to allow easy wiring to the control panel.

Fig. 2

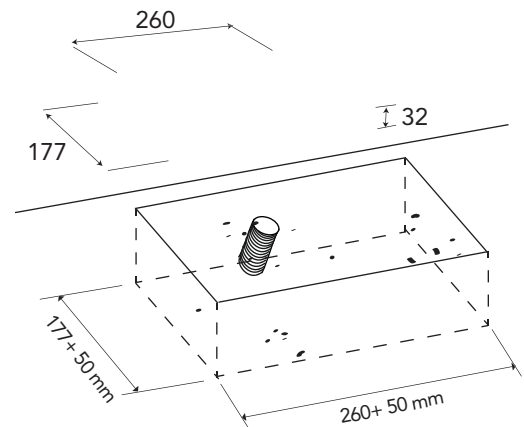
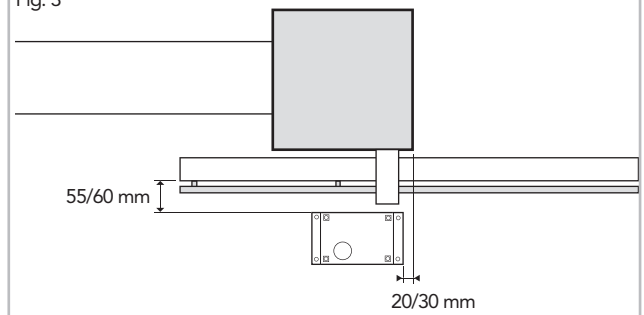

Fig. 3



3.5 INSTALLATION OF THE GEAR MOTOR

- a) Lift up the motor cover.
- b) Insert the four hexagon-headed screws with the washers and nuts in the loops of the motor base (Fig. 4).
- c) Route the electrical cables in the purpose fabricated hole of the motor base (Fig. 5) and gently lower the motor base onto the anchor plate.
- d) Move the screws in the loop's centre and screw them up till the lower nut rests on the anchor plate.
- e) Use a spirit-level to make sure that the gear motor is perfectly level (Fig. 6), if it is not adjust the four screws accordingly. Then tighten all nuts.
- f) Release the gear motor for manual operation as illustrated in section 6 of this manual.

Fig. 4

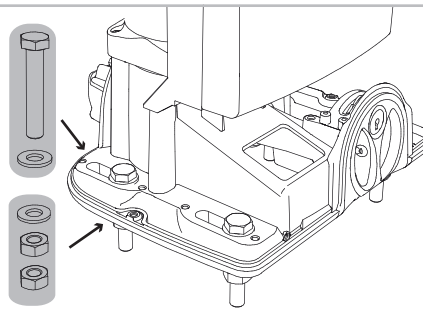

Fig. 5

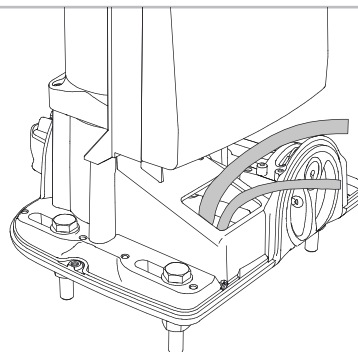

Fig. 6

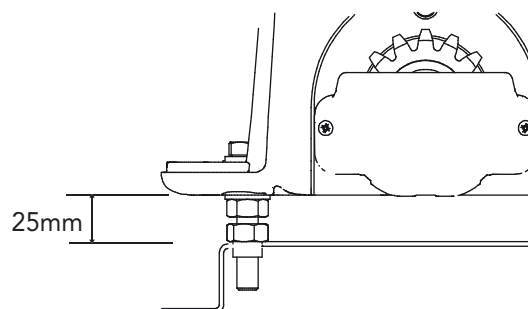
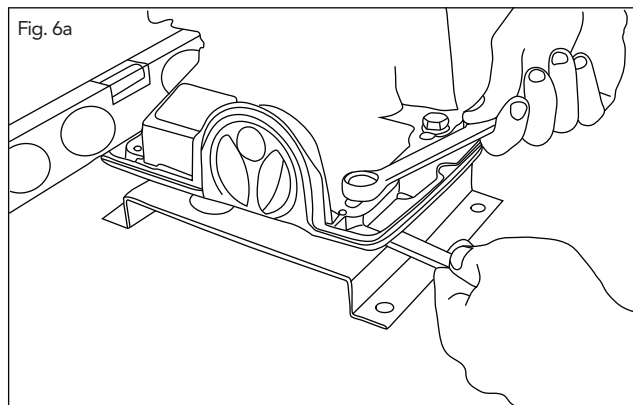

Fig. 6a



3.6 ASSEMBLY THE RACK

3.6.1 INSTALLING THE TOOTHED RACK B120 - PVC RACK M4 20X26MM WITH INNER STEEL FRAME (0.5M SECTIONS)

- a) Move the gate manually to its open position.
- b) Align the first section of the rack to the gate edge and lower it on the pinion. Use a spirit-level to make sure it is perfectly straight.
- c) Fix this first section of rack to the gate with the provided self-tapping screws. Fix the screws in the in the middle of the slot as illustrated (Fig. 7).
- d) Close the gate manually for about ½ meter, join the second section of rack to first one and place it on the motor drive pinion cog.

Fig. 7

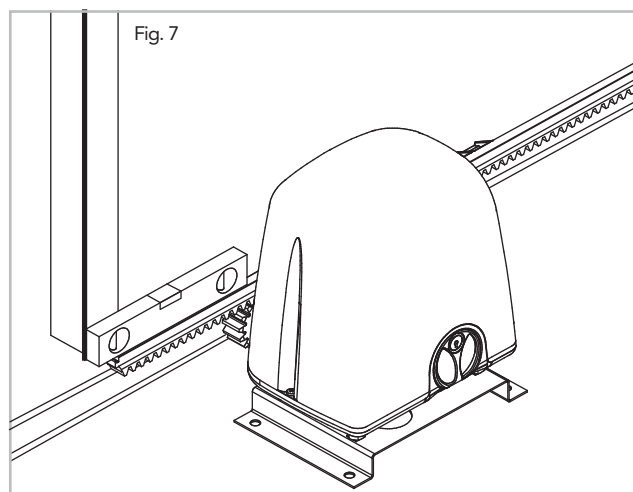

- e) Keep the rack perfectly flat and fix it to the gate.
- f) Repeat the same procedure until the gate is fully covered.
- g) In case the last section of rack partially comes out from the rack edge, do not cut it. Add a bracket as a gate extension to support the last bit of rack (Fig. 8).
- h) To avoid the gates weight being supported by the motors drive pinion cog, adjust the four screws to lower a little the gear motor and then tighten again all the nuts.

3.6.2 WELDING METAL TOOTHED RACK B102 – STEEL RACK M4 12X30MM (1M SECTIONS)

- a) Move the gate manually to its open position.
- b) Assemble the three threaded stand-offs on the first section of rack, positioning in the middle of the slot (Fig. 9).
- c) Align the first section of the rack to the gates edge and lower it on the pinion. Use a spirit-level to ensure the rack is perfectly straight and level.
- d) Weld the threaded stand-off to the gate (Fig. 10)
- e) Move the gate manually, checking that the rack is always resting on the motors drive pinion cog, and weld second and third stand-offs.
- f) Place the second section of rack side by side with the first one, using an upside-down section of rack to synchronise the rack teeth as illustrated in Fig. 11.
- g) Move the gate manually and weld the three threaded stand-offs.
- h) Repeat the same procedure until the gate is fully covered.
- i) In case the last section of rack partially comes out from the rack edge, do not cut it. Add a bracket as a gate extension to support the last bit of rack (Fig.8).
- j) To avoid the gates weight being supported by the motors drive pinion cog, adjust the four screws to lower a little the gear motor and then tighten again all the nuts.

Check the gate always reaches the mechanical stops keeping the alignment between the rack and the motor drive pinion cog. Ensure that there are no friction points in the gates complete travel.

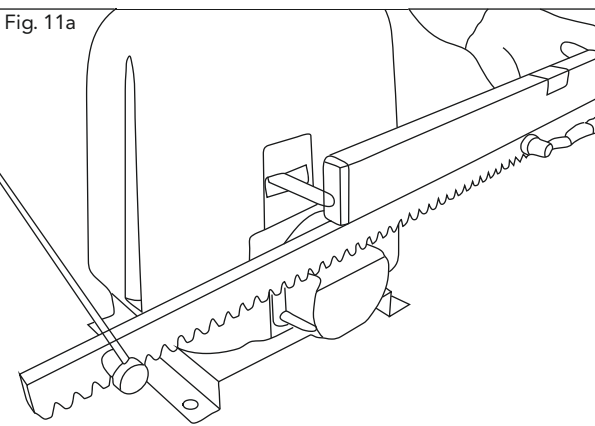
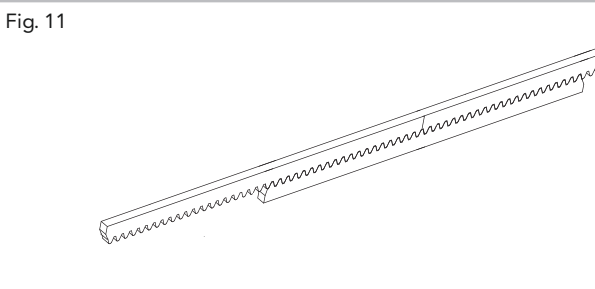
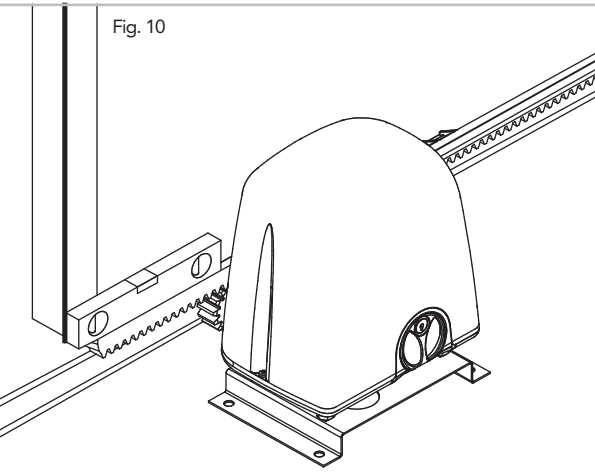
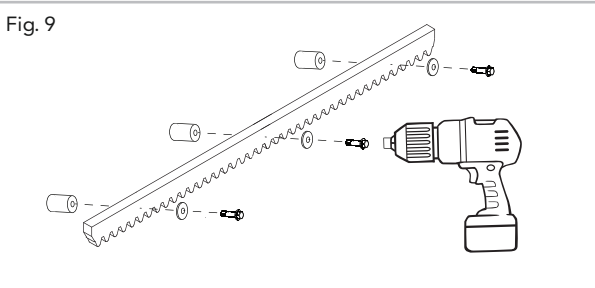
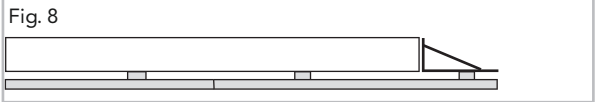
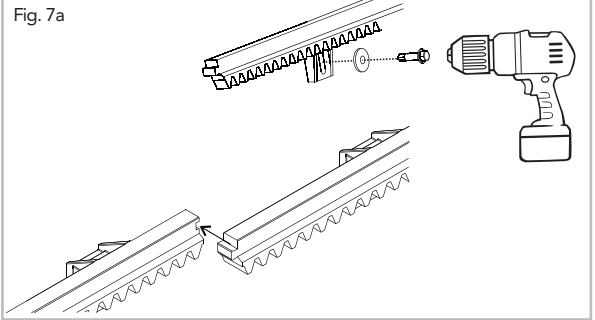

3.7.1 PVC BRACKETS FOR TOOTHED RACK B120

- Identify closing and opening brackets according to the motor position against the gate (Fig. 12).
- Manually close the gate up to 3cm before the closing mechanical stop.
- Place the closing bracket on the rack and slide it until the limit-switch is activated (Fig. 13).
- Mark the bracket position onto the rack, slightly open the gate and fix the bracket to the rack.
- Manually open the gate (gate end aligned to the pillar edge).
- Place the opening bracket on the rack and slide it until the limit-switch is activated (Fig. 14).
- Mark the bracket position onto the rack, slightly close the gate and fix the bracket to the rack.

NB. Tagliare eventuali eccedenze di cremagliera

Fig. 12

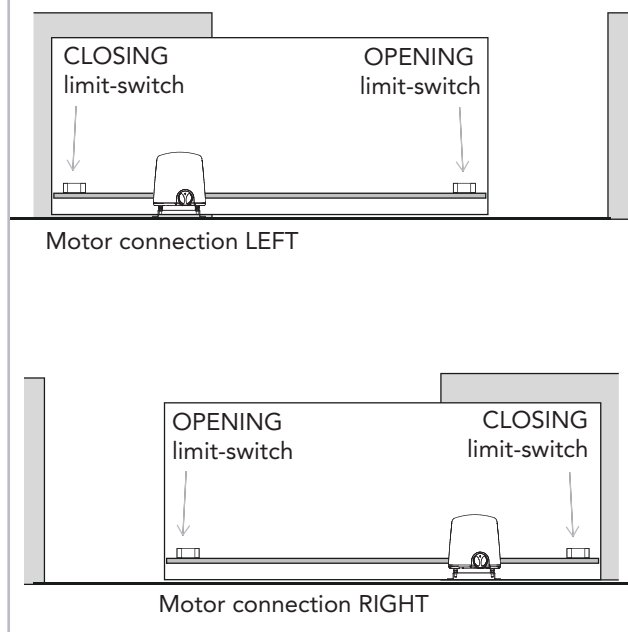

Fig. 13

RIGHT motor OPENING limit-switch

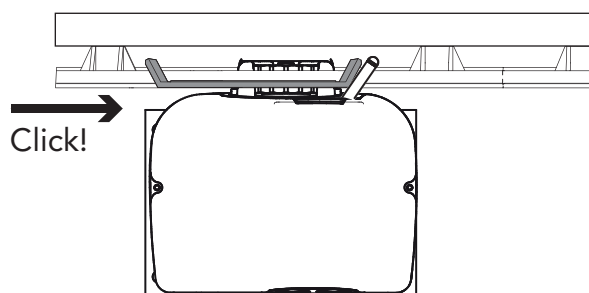
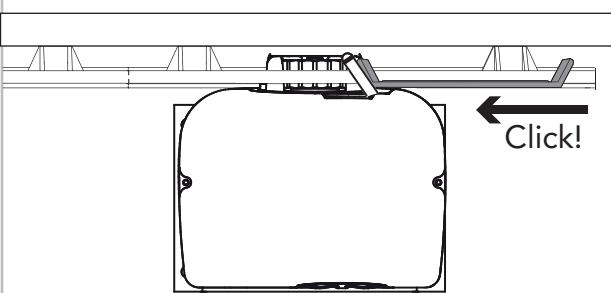

Fig. 14

LEFT motor CLOSING limit-switch



3.7.2 UNIVERSAL STEEL BRACKETS

- Identify closing and opening bracket according to the motor position against the gate (fig. 15).
- Manually close the gate up to 3cm before the closing mechanical stop.
- Put the two fixing screws on the closing limit bracket.
- Place the closing bracket on the rack and slide it until the limit-switch is activated (Fig. 13).
- Tighten the screws to fix the bracket onto the rack.
- Manually open the gate (gate end aligned with the edge of the pillar).
- Put the two fixing screws on the opening limit bracket.
- Place the opening bracket on the rack and slide it until the limit-switch is activated (Fig. 14).
- Tighten the screws to fix the bracket onto the rack.

Fig. 15

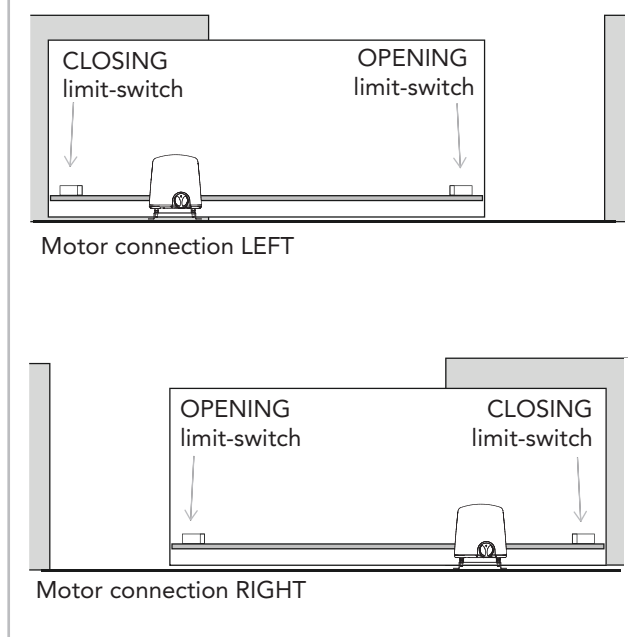

Fig. 13 RIGHT motor OPENING limit-switch

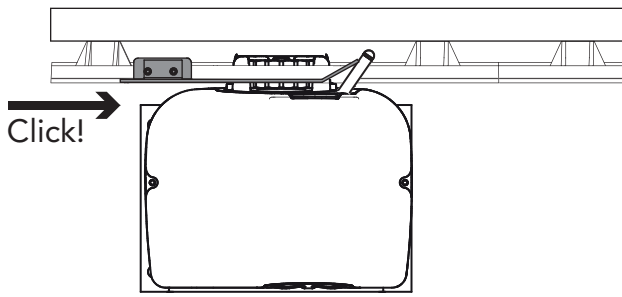
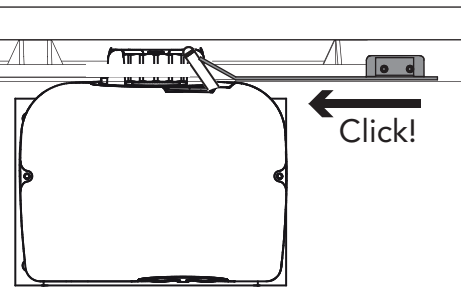

Fig. 14 LEFT motor CLOSING limit-switch



Once the assembling of the limit brackets to rack is completed, open and close the gate manually to check that the brackets always activate the limit-switch system before the gate reach its mechanical stops. This checking is important to preserve the correct working of the automation and continued good mechanical condition of the gate.

NB. Tagliare eventuali eccedenze di cremagliera.

4. ELECTRICAL WIRING

Insert the electrical cables into the control panel's case by piercing the rubber membrane and place the cable grommet in its purpose fabricated seat on the motor's base (Fig. 16).

Terminate the cable of the main supply with the provided cable block (Fig. 17).

Follow the control panel's instruction manual to proceed with the correct cable wiring. Wire all cables for the earth system to the provided lug and fix onto the motor base point marked with \equiv symbol.

Fig. 16

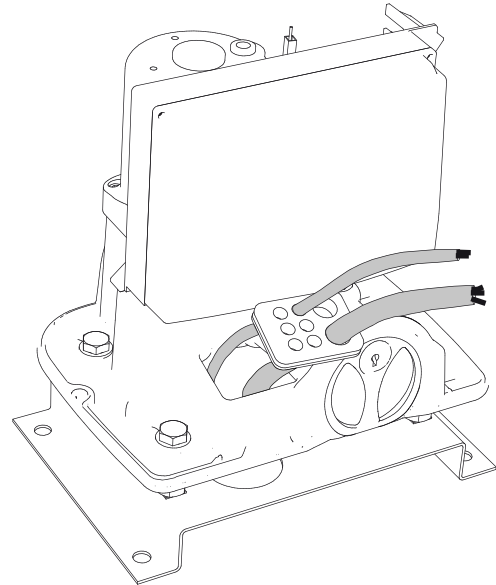

Fig. 17

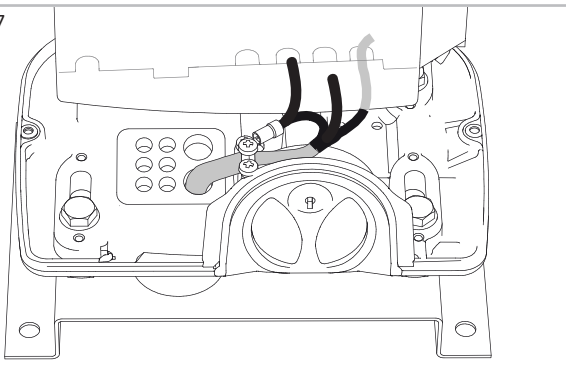
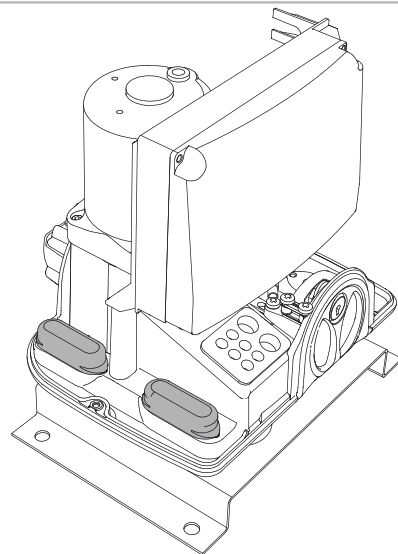

Fig. 18



5. START-UP

Power the system and proceed with a careful checking of the gear motor working and of all the accessories and safety devices connected to the system.

In particular make sure that the electric limit-switch is always activated in opening and closing before the gate reaches its mechanical stops. Place the two slot-covers on the M10 screws. Lift the motor cover down and close it with the two side screws.

Hand over this instructions manual to the end user and demonstrate the correct use of the automation and how to release the motor for manual operation of the gate in the event of power cuts.

6. RELEASE PROCEDURE FOR MANUAL OPERATION

⚠ Always cut the main power of the system during the release and re-locking procedure to avoid any accidental activation of the gate.

6.1 How to unlock the motor for manual operating

- Insert the key into the lock and turn it anti-clockwise (Fig. 19)
- Turn the handle clockwise completely (180°) (Fig.19A)
- Open and close the gate manually as required.

6.2 How to restore the automatic working

- Turn the handle anti-clockwise completely.
- Turn the key clockwise and take it out.
- Manually move the gate until it re-engages the locking system.
- Restore power to the automation system.

⚠ Always keep the release key together with the instruction manual in a safe place.

Fig. 19

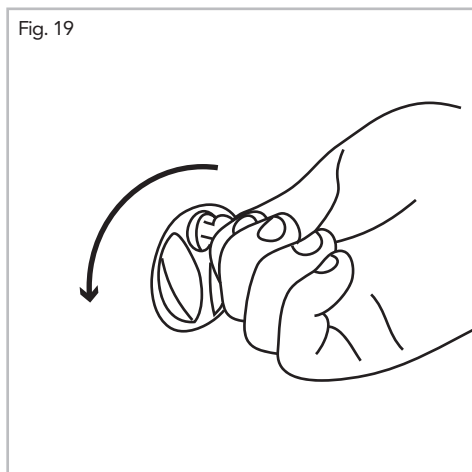
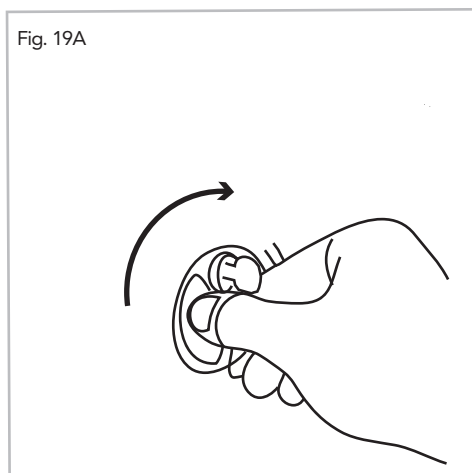

Fig. 19A



7. MAINTENANCE

Check the correct working of the automation at least twice a year, pay particular attention to the safety devices, the torque force produced, the release system for manual operation and to all the mechanical moving parts. Any components displaying significant wear should be obtained from Proteco or associated agents and replaced immediately.

8. DISPOSAL

⚠ Do not pollute the environment

Some components may contain polluting substances. Ensure materials are passed to authorised collection centres, according to the laws and the regulations in force in your locality for safe disposal.



by Proteco S.r.l. Via Neive, 77 - 12050 CASTAGNITO (CN) ITALY
Tel. +39 0173 210111 - Fax +39 0173 210199 - www.mygate.it